



PP2FLAT

Low Energy Positive Input
Ventilation Unit

Installation and Maintenance Manual



Greenwood
AIRVAC

CE The EMC Directive 2004/108/EC
The Low Voltage directive
2006/95/EC

Important notes to installers

The Greenwood PP2FLAT range has been designed to cure severe condensation problems in some of the worst affected properties throughout the world.

Its successful operation depends entirely upon the unit being installed strictly in accordance with these instructions. We would, therefore, respectfully suggest that you read through this guide in its entirety before commencing installation and then go through this guide step by step to ensure a satisfactory completion.

Whilst the installation of the PP2FLAT unit may be achieved by a suitable craftsman, the provision of the electrical supply and the connection of the unit to the mains must be carried out by a qualified electrician.

The unit has a 5 year warranty starting from the day of delivery and includes parts and labour for the first year. The remaining 4 years covers parts only. This warranty is conditional on the following:-

- That the unit is installed strictly in accordance with this guide.
- That the unit filters are removed and cleaned or replaced at the recommended intervals.

The unit represents a significant financial outlay on the part of the user/specifier and the unique 5 year warranty is important to them. We make a point of advising them that the installer is provided with detailed instructions regarding installation/guarantee registration and therefore has the responsibility of ensuring that the unit is guaranteed for the user/specifier.

1.0 Installation

IMPORTANT

Where the systems are installed in flats where regulations require the provision of a protected entrance hall or protected enclosure and the outlet of the systems are within that enclosure it is necessary to ensure that the safety of the enclosure is not compromised either in relation to its fire resistance or the entry of smoke. Smoke detectors must be connected to the fan so that it shuts down if smoke enters the ductwork. Ductwork must be of steel, with the point of fire penetration stopped, or if non fire-resistant ducting is used, it must be protected in fire-resisting construction up to the point where it penetrates the wall of the protected entrance hall or protected enclosure.

Where the systems are installed in flats where these regulatory provisions do not apply, good installation practice should be observed; for example the use of smoke detectors to control the fan, to ensure that occupant safety levels are not reduced.

For more information please refer to the Building Regulations, Approved Document B (Fire safety) – Volume 1: Dwelling houses (2006 Edition)

The unit is designed to take fresh air from outside, clean the air, warm it (if fitted with heater) and discharge it into the central hallway via a system of ducting supplied by the installer.

The dwelling internal air discharge grille is usually installed at high level in a central location within the hallway, although discharging the air down the length of the hallway (away from the front door) should also prove acceptable. Unit performance may be enhanced if an existing heat source can warm the discharged air eg. by locating the discharge grille above a radiator.

Before commencing installation decide the best position for the unit and where the fresh air input air is to come from and be discharged to. The unit can be installed in many different configurations and is supplied with enough interchangeable spigots to enable it to be used with either round (100mm) or rectangular ducting (121mm x 60mm). The unit can be turned through 180° to any angle if required.

Figure 1. Typical installations show unit with top discharge.

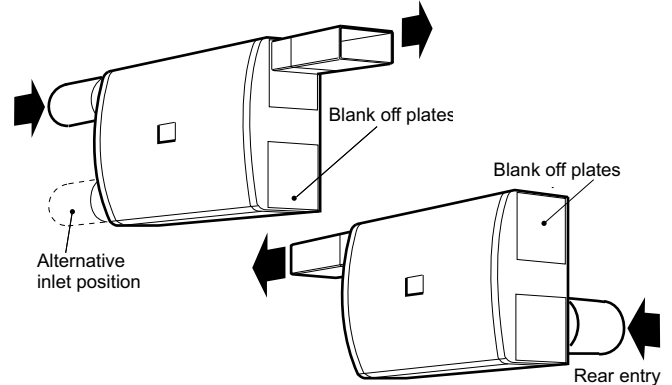

Fixing the unit to the wall

The unit has four mounting pads. Mark through these pads when the unit is in the correct position. Drill and plug wall with suitable fixings. Remove PCB cover and feed the electrical supply cable through the grommet hole (standard 1mm three core lighting cable is recommended) in the rear of the unit screw unit to wall.

Points to consider

- The inlet ducting should be kept as short as possible to avoid condensation build up on the ducting surface (see figs 5/6).
- Can the discharge grille be located to take advantage of existing heat sources?
- Find the shortest, most direct route from outside of the unit and then to the discharge grille using the least number of bends (these bends increase the airflow resistance).
- Note the location of any joists, pipes, electrical cables etc.
- Allow adequate access to the front cover to allow filter cleaning?
- Refer to the relevant Building and Electrical Regulations.

Setting up the correct airflow direction

Figure 2.

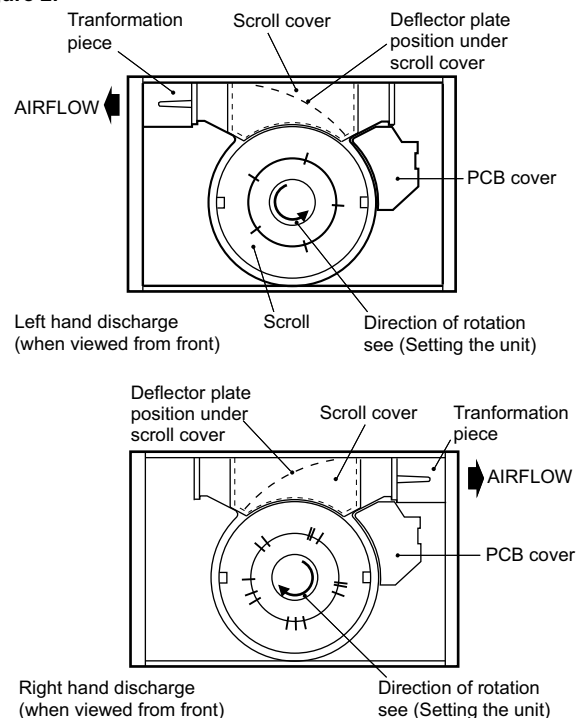

Fitting the deflector plate

Fit deflector plate into scroll cover as shown below. Once fitted the assembly can be slotted into the scroll and clipped firmly in place.

Figure 3.

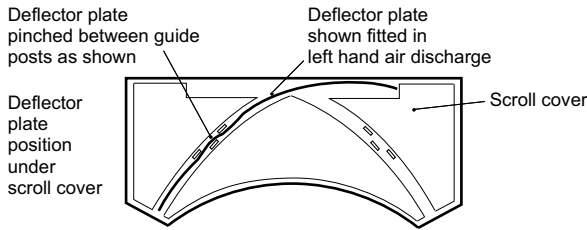

Deflector plate shown fitted for left hand air discharge (viewed from inside)

Transformation Piece

This should be on the appropriate scroll outlet. The transformation piece should be fitted into the chosen outlet spigot insert, prior to fitting.

Note: If the round spigot is used as an outlet, the 115 x 55mm clear blanking plate will need to be fitted (as shown). This plate should be prevented from movement by the use of silicone sealant.

Figure 4.

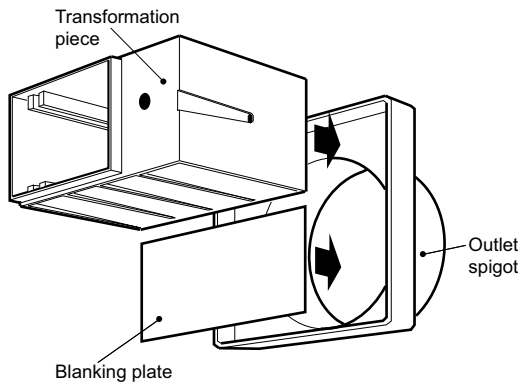

Inlet/Outlet Grille installation

IMPORTANT

The internal grille must not be placed within 1.5m of a smoke alarm.

If a flyscreen is fitted it should be removed from both the internal and external grille.

NOTE: When installing the internal grille, the louvres **must slant upwards** to ensure the correct air circulation and the avoidance of unpleasant downdraughts.

The outside wall input grille louvres **must slant downwards**.

Standard 100mm dia ducting or 121 x 60mm ducting is used to connect the unit to the input and discharge grilles.

Figure 5. Side input installation.

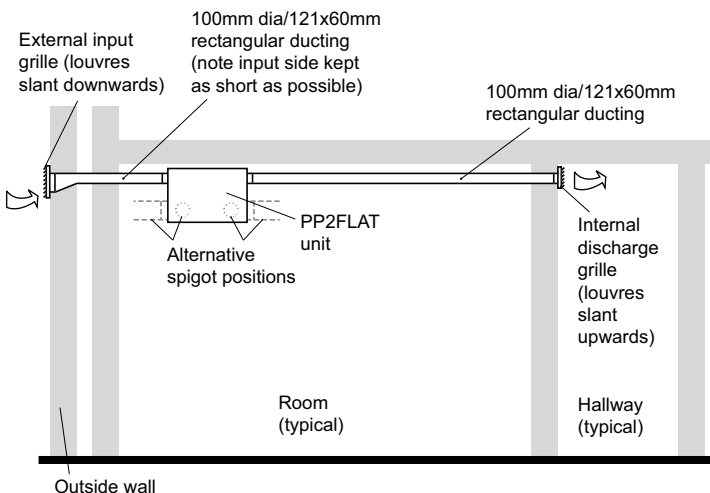
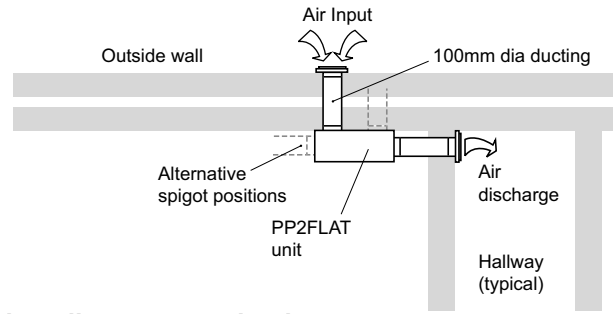

Figure 6. Rear input installation (view from above).



Fixing all necessary ducting

A full range of ductwork and ductwork ancillaries are available. Please contact Greenwood for further details.

2.0 Electrical details

Supply - 230V 1 phase 50Hz.

Power Consumption

Speed 1 - 5 Watts

Speed 2 - 8 Watts

Speed 3 - 13 Watts

The unit should be wired in accordance with current IEE regulations.

Electrical connection

Please note the electrical connections to the unit should be carried out by a qualified electrician.

With the PCB cover removed (see figure 2) pull the PCB forward to gain access to earth post behind. Connect Earth cable to Earth Post next to the grommet hole. (If the heater option is required the wiring should be connected to the appropriate terminal on the PCB).

Slide PCB into slot and connect the mains supply L and N to the terminal block.

IMPORTANT

For good EMC engineering practice, any sensor cables or switched live cables should not be placed within 50mm of other cables or on the same metal cable tray as other cables.

2.1 Smoke alarm automatic shut down

If the unit is required to switch off in the event of smoke detection, alarms are available with separate relay bases from companies such as:

Dicon Safety products – www.diconsafety.co.uk

Aico Ltd – www.aico.co.uk

Figure 10. Typical wiring (refer to manufactures specific instructions).

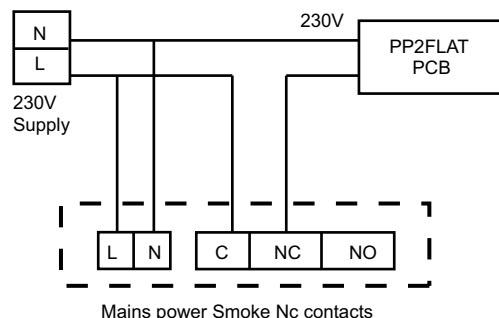

3.0 Setting the Unit

The speed selector is located on the PCB (see bathroom application figure 11) The unit has a choice of three speeds to suit the size of the dwelling and the moisture being generated. The unit is factory set at No 3. We recommend that the unit is operated at this speed and the setting reduced if and when necessary in the future.

Replace PCB cover and test the unit. Check rotation of fan with diagrams under airflow direction. If direction is incorrect, isolate the unit, remove PCB cover and alter the rotation switch (mounted on the PCB). Replace PCB cover and re-check direction of fan. Replace filter and front cover.

Figure 11. PCB Panel (viewed end on).

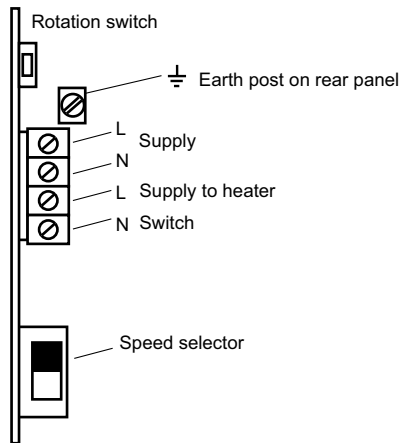

4.0 Maintenance

The only maintenance required is the removal and cleaning of the filter every 12 months to 2 years. (The filter can also be vacuum cleaned).

IMPORTANT

Any air intake terminal MUST be installed in accordance with the appropriate regulation.

As a guide, the BS5440 series of British Standards deals with this issue and currently states that an air intake must be at a minimum distance of 300mm from a gas boiler balanced flue. Installers are advised to be aware of the requirements of this standard when installing 'through the wall' supply air ducting.

Similarly, supply and extract air grilles should be at least 300mm apart.

Users Guide

Q. What is a PP2FLAT Home Improvement Unit?

- A. It is a small wall mounted, air cleaning/moving device that continuously inputs filtered fresh air into the dwelling from outside.

Q. What does the unit do?

- A. The unit will cure and/or prevent the problems associated with condensation in your home, providing a cleaner, healthier living environment for all occupants. The unit will prevent mould growth on walls, ceilings, furniture, clothes and curtains. The unit also eradicates the musty smells evident in homes with severe condensation problems.

Q. How does it work?

- A. Simply and very efficiently. Outside air is drawn into the unit, filtered and then ducted into a central area (typically the hallway/stairwell) of the dwelling. However, the performance of the unit may be enhanced if an existing heat source can be mixed with the discharged air. For instance, the unit could be mounted to discharge into an airing cupboard. The cupboard would then have an outlet grille fitted in the top of its sidewall to supply tempered air into the dwelling. As the air is supplied into the dwelling it mixes with the warmer air that naturally accumulates at ceiling level taking advantage of the heat from this warm air you have paid for but are not making use of. This tempered, fresh, clean air then continuously and gently dilutes, displaces and replaces the air within your home. The result is a home free from serious condensation and a more pleasant and comfortable environment.

Q. How much does it cost to run?

- A. When you consider the advantages the unit will provide for you and the other occupants, the running costs are insignificant. However, it should be remembered that the unit is making use of heat at ceiling level that would otherwise be lost.

Q. How do I operate the unit?

- A. You don't have to. From the time the installer starts the unit it will run continuously for many years of trouble free use.

Q. What maintenance is required for the unit?

- A. Very little. The only maintenance required is the removal and cleaning of the filter every 12 months to 2 years. (The filter can also be vacuum cleaned).

Q. How will I remember to clean the filters?

- A. When the filters become dirty, the unit does not input as much air into the dwelling. Condensation and musty smells may become evident. This will be a signal for you to check and clean or replace the filters as necessary.

Q. How will I know if the unit is working?

- A. The unit motor may be almost inaudible but you should notice a change of atmosphere in the hallway within a day or so. Within a few weeks any mould should start to dry out and eventually become a grey powder which can easily be cleaned. After a month your home will be a healthier environment free from severe condensation dampness and probably more efficient.

Q. What do I do if the unit stops working?

- A. If the unit appears to have stopped operating please contact our:

**Technical Services Department
01903 777135**

If you are a Housing Association or Local Authority tenant however, you should contact your Local Housing Office in the first instance.

Units fitted with heater

Some units are fitted with a heater to temper the incoming air. A heater neon indicator switch (normally mounted on the side of the unit) is provided on these models. You can choose when you wish to use the heater.

The installation must only be examined by a qualified electrician and must always be isolated before an inspection. Under no circumstances must the unit be dismantled as this will invalidate the warranty.

Useful tips

To ensure you get the maximum benefit from your Greenwood PP2FLAT Home Improvement unit:

1. Avoid drying clothes on radiators or indoor clothes lines.
2. Avoid having tumble dryers venting into your home. Always vent to outside.
3. Avoid using portable unflued gas heaters.
4. Avoid using paraffin heaters.

Finally, thank you for taking the time to read this short user guide. If you are happy with your PP2FLAT Home Improvement Unit, please tell your friends and neighbours.

If you are not - Please tell us.